

CUSTOM PRINT

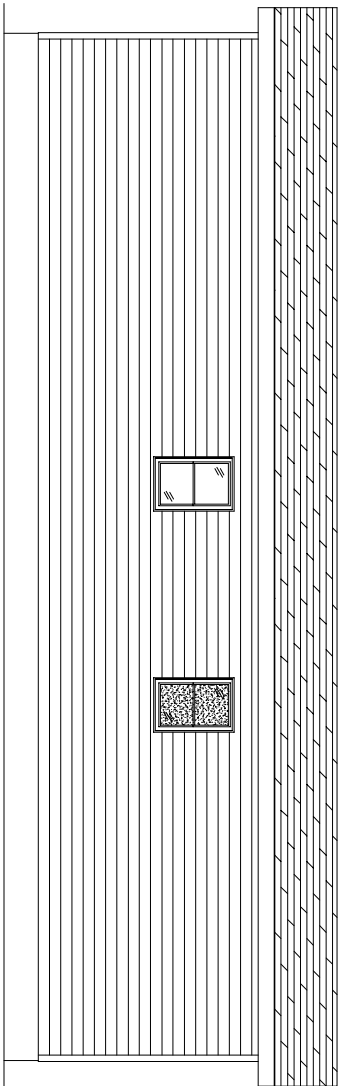
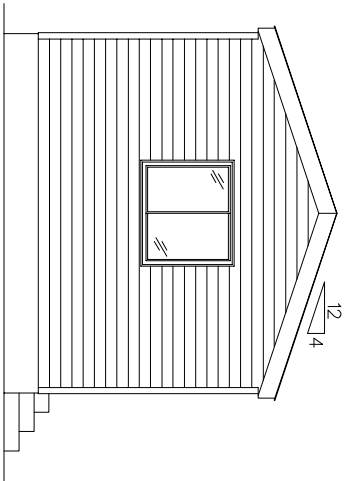
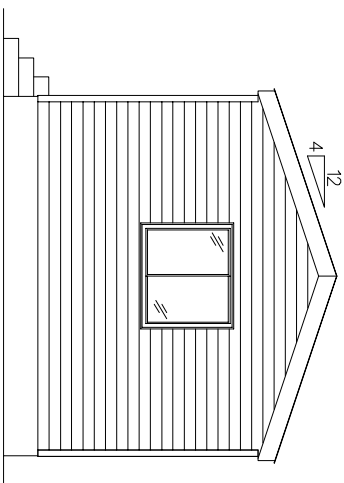
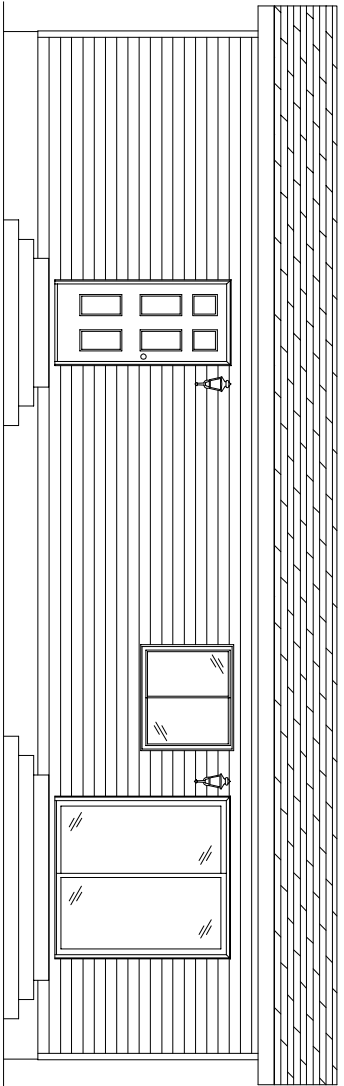

NOTES: MODULE ASSUMES NO RESPONSIBILITY FOR
FIRE SEPARATION, SEISMIC OR DOOR/WINDOW
FENESTRATION REQUIREMENTS. CONSULT YOUR LOCAL
BUILDING OFFICIAL OR ENGINEER OF RECORD TO CONFIRM
NOTE: SHOWN OPTIONS ARE NOT INCLUDED IN PRICING

Any renderings and depictions are conceptual only and are for the convenience of reference. They should not be relied upon as representations, express or implied, of the final detail of the Units. Moduline Industries expressly reserves the right to make modifications, revisions, and changes it deems desirable in its sole and absolute discretion. All depictions of appliances, counters, furniture, finishes, lighting, plumbing fixtures, soffits, floor coverings and other matters of detail are conceptual only and are not necessarily included in each Unit. Consult your Purchase Agreement and the Offering Documents for the Items included with the Unit. Dimensions and square footage are approximate and may vary with actual construction.

MODULINE INDUSTRIES
P.O. BOX 190
1175 RAILWAY STREET
PENNINGTON, B.C. V2A 6K3
(250) 393-0122

CUSTOMER: _____ SIGN _____
DEALER: _____ SIGN _____
DATE: _____

DEALER CHANGE REQUEST	
A	
B	
C	

TITLE: **PACIFIC CABIN**
DRAWING NO. **09829A - (14736)**
DRAWN BY: _____ K.E.A.
DATE: 06/30/2016